

# Turmdrehkran

Tower Crane / Grue à tour / Gru a torre / Grúa torre  
Guindaste de torre / Башенный поворотный кран

## 90 EC-B 6 FR.tronic®

**90 EC-B 6**

▶ **90 EC-B 6 FR.tronic®**

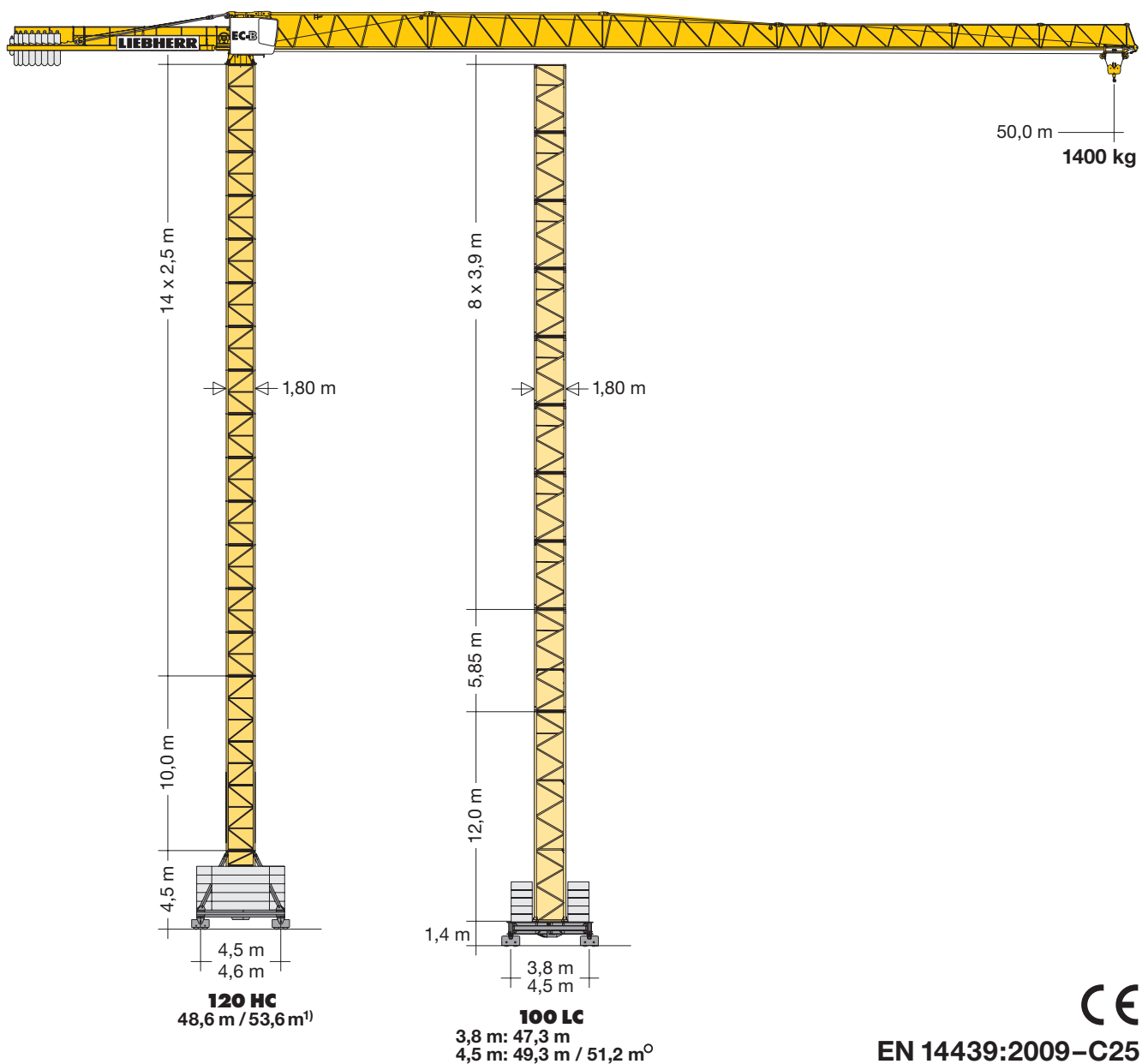

CE

EN 14439:2009-C25

# LIEBHERR

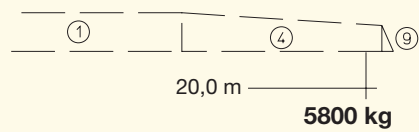
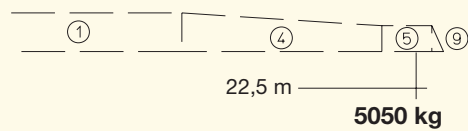
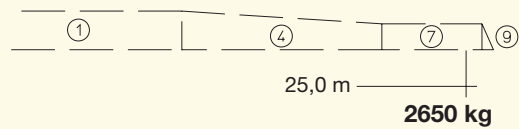
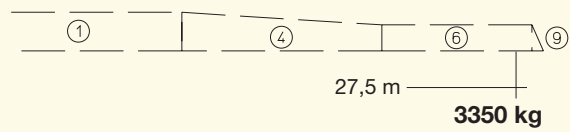
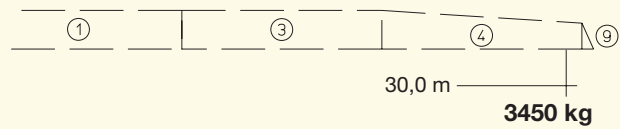
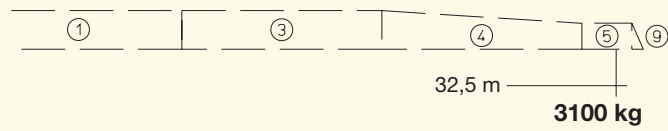
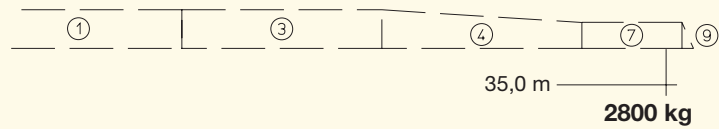
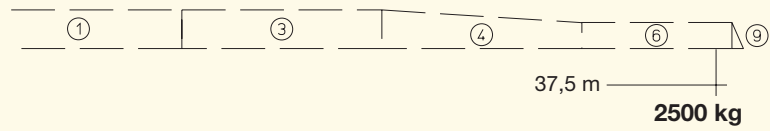
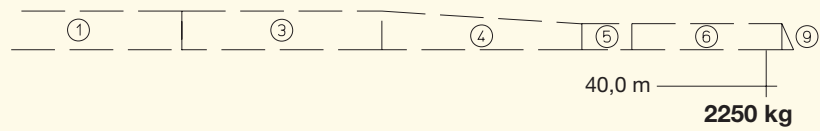
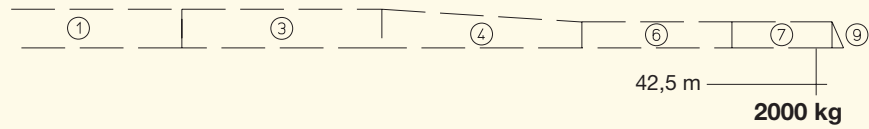
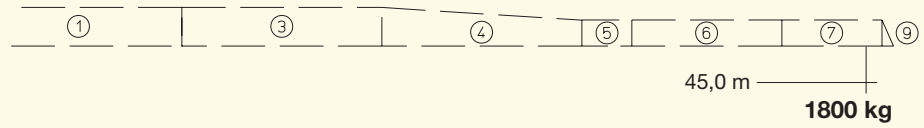
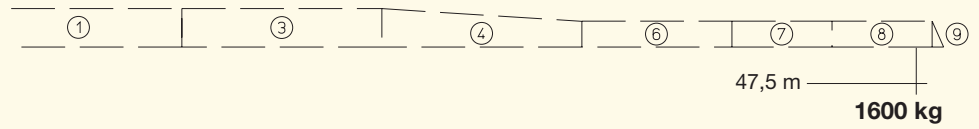
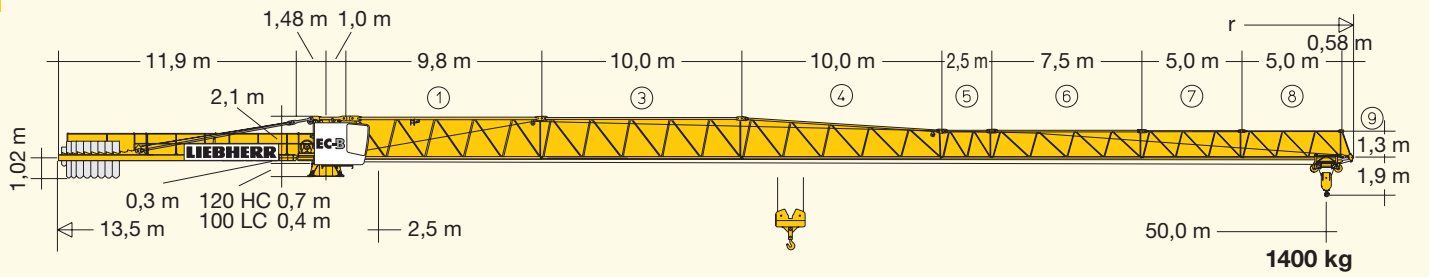

## 90 EC-B 6 FR.tronic®

m	r	m/kg	m/kg														
			15,0	17,5	20,0	22,5	25,0	27,5	30,0	32,5	35,0	37,5	40,0	42,5	45,0	47,5	50,0
50,0	(r = 51,5)	2,5-15,4 6000	6000	5220	4480	3910	3460	3080	2770	2510	2280	2090	1920	1760	1630	1510	1400
47,5	(r = 49,0)	2,5-16,1 6000	6000	5460	4700	4110	3630	3240	2920	2640	2410	2200	2020	1870	1730	1600	
45,0	(r = 46,5)	2,5-16,6 6000	6000	5660	4870	4260	3770	3360	3030	2750	2500	2290	2110	1950	1800		
42,5	(r = 44,0)	2,5-16,9 6000	6000	5790	4990	4360	3860	3450	3110	2820	2570	2350	2170	2000			
40,0	(r = 41,5)	2,5-17,5 6000	6000	5980	5150	4510	3990	3570	3220	2920	2670	2440	2250				
37,5	(r = 39,0)	2,5-17,8 6000	6000	6000	5260	4600	4080	3650	3290	2990	2730	2500					
35,0	(r = 36,5)	2,5-18,2 6000	6000	6000	5390	4720	4180	3740	3380	3070	2800						
32,5	(r = 34,0)	2,5-18,3 6000	6000	6000	5440	4770	4230	3780	3410	3100							
30,0	(r = 31,5)	2,5-18,5 6000	6000	6000	5500	4820	4270	3820	3450								
27,5	(r = 29,0)	2,5-16,5 6000	6000	5640	4850	4240	3750	3350									
25,0	(r = 26,5)	2,5-12,4 6000	4850	4070	3480	3020	2650										
22,5	(r = 24,0)	2,5-19,3 6000	6000	6000	5760	5050											
20,0	(r = 21,5)	2,5-19,4 6000	6000	6000	5800												

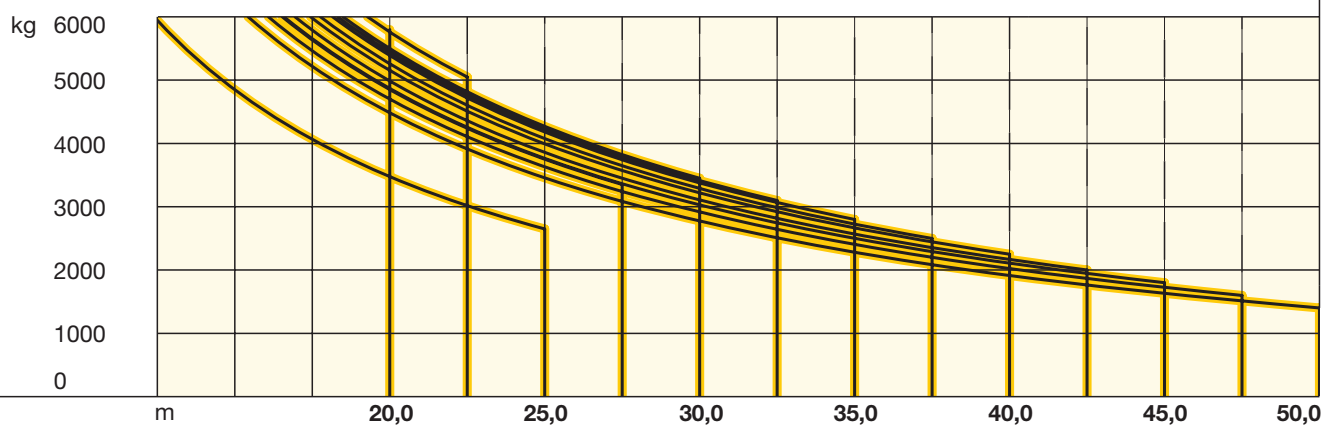

3,9m + 5,85m		5,85m	11,7m	<b>100 LC</b>														
3,9m		5,85m	11,7m	C 25														
12		8		-	47,4°	-	-	47,6°	-	-	47,7°	-	-	47,0°	-	-	45,8°	-
11	10+1			-	45,5	-	-	45,7	-	-	45,8	-	-	45,1	-	-	43,9	-
10	9+1	7		43,5	43,5	-	-	43,7	-	-	43,8	-	-	43,1	-	-	42,0	-
9	8+1	6	3	41,6	41,6	-	-	41,8	53,4°	53,4°	41,9	53,5°	53,5°	41,2	52,8°	52,8°	40,0	52,0°
8	7+1	5		39,6	39,6	-	51,2°	39,8	51,4°	51,4	39,9	51,5°	51,5	39,2	50,8°	50,8	38,1	50,0
7	6+1	4	2	37,7	37,7	-	-	37,9	49,5	49,5	38,0	49,6	49,6	37,3	48,9	48,9	36,1	48,1
6	5+1	3		35,7	35,7	47,3	47,3	35,9	47,5	47,5	36,0	47,6	47,6	35,3	46,9	46,9	34,2	46,1
5	4+1	2		33,8	33,8	45,4	45,4	34,0	45,6	45,6	34,1	45,7	45,7	33,4	45,0	45,0	32,2	44,2
4	3+1	1		31,8	31,8	43,4	43,4	32,0	43,6	43,6	32,1	43,7	43,7	31,4	43,0	43,0	30,3	42,2
3	2+1			29,9	29,9	41,5	41,5	30,1	41,7	41,7	30,2	41,8	41,8	29,5	41,1	41,1	28,3	40,3
2	1+1			27,9	27,9	39,5	39,5	28,1	39,7	39,7	28,2	39,8	39,8	27,5	39,1	39,1	26,4	38,3
1	0+1			26,0	26,0	37,6	37,6	26,2	37,8	37,8	26,3	37,9	37,9	25,6	37,2	37,2	24,4	36,4
0	0	0	0	24,0	24,0	35,6	35,6	24,2	35,8	35,8	24,3	35,9	35,9	23,6	35,2	35,2	22,5	34,4
				22,1	22,1	33,7	33,7	22,3	33,9	33,9	22,4	34,0	34,0	21,7	33,3	33,3	20,5	32,5
				20,1	20,1	31,7	31,7	20,3	31,9	31,9	20,4	32,0	32,0	19,7	31,3	31,3	18,6	30,5
				18,2	18,2	29,8	29,8	18,4	30,0	30,0	18,5	30,1	30,1	17,8	29,4	29,4	16,6	28,6
				16,2	16,2	27,8	27,8	16,4	28,0	28,0	16,5	28,1	28,1	15,8	27,4	27,4	14,7	26,6
				14,3	14,3	25,9	25,9	14,5	26,1	26,1	14,6	26,2	26,2	13,9	25,5	25,5	12,7	24,7
				12,3	12,3	23,9	23,9	12,5	24,1	24,1	12,6	24,2	24,2	11,9	23,5	23,5	10,8	22,7
				10,4	10,4	22,0	22,0	10,6	22,2	22,2	10,7	22,3	22,3	10,0	21,6	21,6	8,8	20,8
				8,4	8,4	20,0	20,0	8,6	20,2	20,2	8,7	20,3	20,3	8,0	19,6	19,6	6,9	18,8
				6,5	6,5	18,1	18,1	6,7	18,3	18,3	6,8	18,4	18,4	6,1	17,7	17,7	4,9	16,9
				4,5	4,5	16,1	16,1	4,7	16,3	16,3	4,8	16,4	16,4	4,1	16,7	16,7	3,0	14,9
				-	-	12,2	12,2	-	12,4	12,4	-	12,5	12,5	-	11,8	11,8	-	11,0

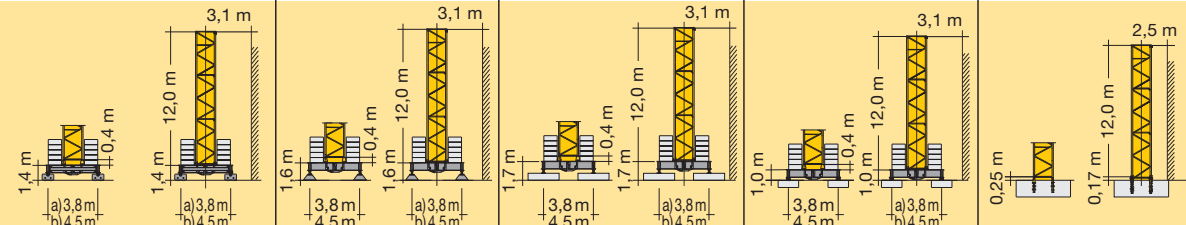

○ = Ohne Kabine / Without cabin / Sans cabine / Senza cabina / Sin cabina / Sem cabine / Без кабины

Weitere Hubhöhen sowie Klettern auf Anfrage. / Further hoist heights and climbing on request. / Hauteurs sous crochet plus élevées et hissage sur demande. / Altre altezze di sollevamento come pure telescopaggio, su richiesta. / Para alturas bajo gancho superiores y trepado, consultar. Outras alturas de elevação e ascensionamento, mediante consulta. / Другие высоты подъема и наращивание крана – по запросу.

		<b>120 HC</b>												
		C 25												
17	53,0 <sup>1)</sup>	-	52,5 <sup>1)</sup>	-	48,7 <sup>3)</sup>	51,8 <sup>3)</sup>	-	-	50,2 <sup>3)</sup>	53,3 <sup>5)</sup>	50,0 <sup>3)</sup>	53,1 <sup>3)</sup>	50,0 <sup>3)</sup>	53,1 <sup>3)</sup>
16	50,5 <sup>2)</sup>	53,6 <sup>1)</sup>	50,0 <sup>2)</sup>	53,1 <sup>1)</sup>	46,2 <sup>2)</sup>	49,3 <sup>2)</sup>	47,7 <sup>1)</sup>	-	47,7 <sup>2)</sup>	50,8 <sup>3)</sup>	47,5 <sup>2)</sup>	50,6 <sup>2)</sup>	47,5 <sup>2)</sup>	50,6 <sup>3)</sup>
15	48,0 <sup>2)</sup>	51,1 <sup>3)</sup>	47,5 <sup>2)</sup>	50,6 <sup>3)</sup>	43,7 <sup>2)</sup>	46,8 <sup>2)</sup>	45,2 <sup>4)</sup>	48,3 <sup>3)</sup>	45,2 <sup>2)</sup>	48,3 <sup>2)</sup>	45,0 <sup>2)</sup>	48,1 <sup>2)</sup>	45,0 <sup>2)</sup>	48,1 <sup>2)</sup>
14	45,5 <sup>2)</sup>	48,6 <sup>2)</sup>	45,0 <sup>2)</sup>	48,1 <sup>2)</sup>	41,2 <sup>2)</sup>	44,3 <sup>2)</sup>	42,7 <sup>2)</sup>	45,8 <sup>2)</sup>	42,7 <sup>2)</sup>	45,8 <sup>2)</sup>	42,5 <sup>2)</sup>	45,6 <sup>2)</sup>	42,5 <sup>2)</sup>	45,6 <sup>2)</sup>
13	43,0	46,1 <sup>2)</sup>	42,5	45,6 <sup>2)</sup>	38,7	41,8	40,2 <sup>2)</sup>	43,3 <sup>2)</sup>	40,2	43,3 <sup>2)</sup>	40,0	43,1	40,0	43,1 <sup>2)</sup>
12	40,5	43,6	40,0	43,1	36,2	39,3	37,7	40,8	37,7	40,8	37,5	40,6	37,5	40,6
11	38,0	41,1	37,5	40,6	33,7	36,8	35,2	38,3	35,2	38,3	35,0	38,1	35,0	38,1
10	35,5	38,6	35,0	38,1	31,2	34,3	32,7	35,8	32,7	35,8	32,5	35,6	32,5	35,6
9	33,0	36,1	32,5	35,6	28,7	31,8	30,2	33,3	30,2	33,3	30,0	33,1	30,0	33,1
8	30,5	33,6	30,0	33,1	26,2	29,3	27,7	30,8	27,7	30,8	27,5	30,6	27,5	30,6
7	28,0	31,1	27,5	30,6	23,7	26,8	25,2	28,3	25,2	28,3	25,0	28,1	25,0	28,1
6	25,5	28,6	25,0	28,1	21,2	24,3	22,7	25,8	22,7	25,8	22,5	25,6	22,5	25,6
5	23,0	26,1	22,5	25,6	18,7	21,8	20,2	23,3	20,2	23,3	20,0	23,1	20,0	23,1
4	20,5	23,6	20,0	23,1	16,2	19,3	17,7	20,8	17,7	20,8	17,5	20,6	17,5	20,6
3	18,0	21,1	17,5	20,6	13,7	16,8	15,2	18,3	15,2	18,3	15,0	18,1	15,0	18,1
2	15,5	18,6	15,0	18,1	11,2	14,3	12,7	15,8	12,7	15,8	12,5	15,6	12,5	15,6
1	13,0	16,1	12,5	15,6	8,7	11,8	10,2	13,3	10,2	13,3	10,0	13,1	10,0	13,1
0	10,5	13,6	10,0	13,1	6,2	9,3	7,7	10,8	7,7	10,8	7,5	10,6	7,5	10,6

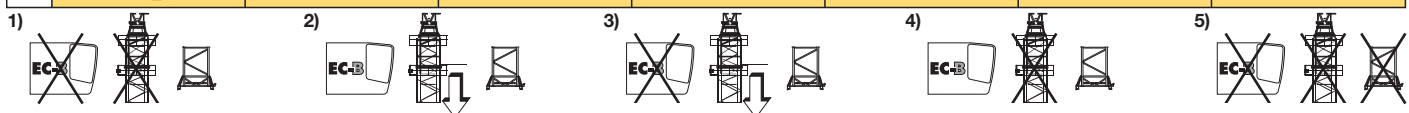
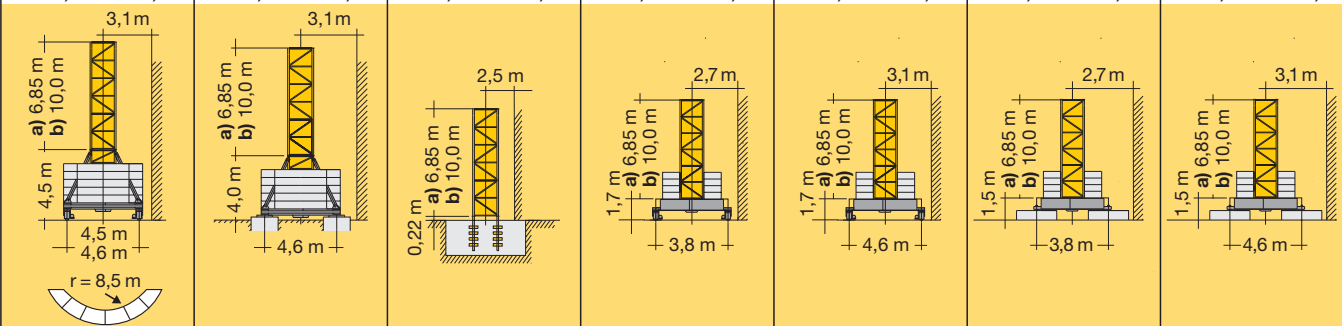

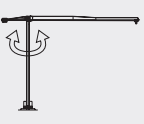
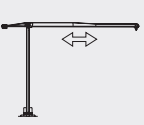
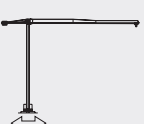
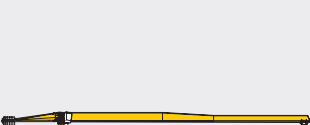

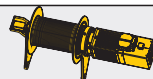
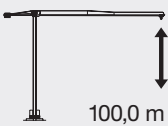
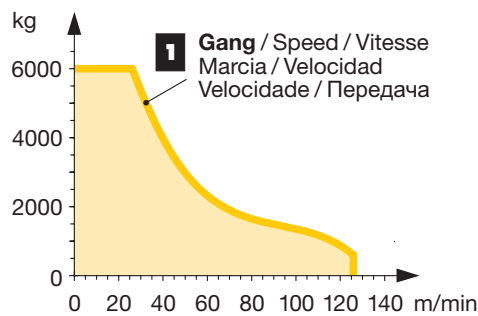











	U/min 0 ↔ 0,8 sl./min tr./min	7,5 kW FU
	0 ↔ 63,0 m/min 0 ↔ 80,0 m/min	3,0 kW FU 5,4 kW FU
	25,0 m/min	2 x 4,0 kW
	<b>kVA</b>	30 kW FU 33,0

	↔ <b>stufenlos</b> / stepless / régl. continu régl. progressive / sin escalones / sem degraus бесступенчатый kg m/min
30 kW FU WIW 240 MZ 403   100,0 m  5 <b>Lagen</b> Layers Couches Avvolgimenti Camadas Сараs Слоёв	<b>1</b> 6000 0 ↔ 26 550 0 ↔ 126
max. 174,0 m**	
	<b>1</b> <b>Gang</b> / Speed / Vitesse Marcia / Velocidad Velocidade / Передача

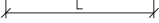
\*\* **Weitere Hublastdaten: siehe Betriebsanleitung.** / Further hoist load data: see instruction manual. / Autres données de la charge de levage: voir manuel d'instruction. / Altri dati sui carichi sollevati: consultare il manuale d'istruzione. / Alturas bajo grancho superiores según manual. / Outras tabelas de carga: consultar manual de instruções. / Другие данные по весу поднимаемых грузов: см. инструкцию по эксплуатации.

**Kolli-Liste** Packing List / Liste de colisage / Lista dei colli / Lista de contenido / Lista de embalagem / Упаковочный лист

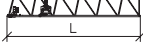
Montagegewichte: siehe Betriebsanleitung. / Erection weights: see instruction manual. / Poids de montage: voir manuel de service. / Pesi di montaggio: vedere manuale d'uso. / Peso para el montaje: según manual. / Pesos de montagem: veja em suas instruções p. uso. / Масса монтируемых частей: см. инструкцию по эксплуатации.

<b>Kranoberteil</b>		Upper part of crane / Partie supérieure de grue / Parte superiore della gru / Parte superior grúa / Parte superior do guindaste / Верхняя часть крана	L (m)	B (m)	H (m)	kg*		
Pos. Item	Anz. Qty.	<b>Drehbühne mit Podesten</b> / Slewing platform with platforms Plate-forme tournante avec plates-formes / Piattaforma girevole con pedana / Plataforma giratoria con plataforma / Plataforma giratória com plataforma / Поворотная платформа с площадками			2,71	2,90	2,58	6220
1	1							
2	1	<b>Drehbühne</b> / Slewing platform / Ensemble mât-cabine / Piattaforma girevole / Conjunto plataforma de giro / Plataforma giratória / Поворотная платформа			2,71	2,25	2,58	5940
3	1	<b>Podeste</b> / Platformes / Plates-formes Pedana / Plataformas / Plataformas / Площадки			2,33 2,40 2,33	0,50 1,04 0,65	1,36 1,33 1,36	120 150 120
4	1	<b>Kabine</b> / Cabin / Cabine Cabina / Cabina / Cabina / Кабина			1,35	2,82	2,28	610
5	1	<b>Gegenausleger</b> / Counter-jib / Contre-flèche Controfreccia / Contrapluma / Contra-lança / Консоль противовеса			11,98	1,40	0,81	2720
6	1	<b>Podeste Gegenausleger</b> / Counter-jib platforms Plates-formes de contre-flèche / Ballatoi controfreccia / Plataforma contrapluma / Plataforma contra-lança / Площадки консоли противовеса			4,00	0,69	1,35	180
7	1	<b>Ausleger-Anlenkstück</b> / Jib heel section / Pied de flèche Sezione articolata braccio / Pluma tramo primero / Base articulada de lança / Корневая секция стрелы			10,01	1,34	2,23	① 2010

Pos. Item Rep. Voce Pos. Ref. Pos.	Anz. Qty. Qte. Qta. Cant. Cant. Cant.				L (m)	B (m)	H (m)	kg*
8	1	<b>Ausleger-Zwischenstück</b> / Intermediate jib section Elément intermédiaire de flèche / Sezione intermedia braccio / Tramo intermedio pluma / Peça complementar da lança / Промежуточная секция стрелы			10,26 2,72 7,71 5,19 5,17	1,20 1,20 1,20 1,20 1,20	2,14 1,48 1,48 1,46 1,45	③ 1180 ⑤ 200 ⑥ 500 ⑦ 230 ⑧ 200
9	1	<b>Ausleger-Zwischenstück</b> / Intermediate jib section Elément intermédiaire de flèche / Sezione intermedia braccio / Tramo intermedio pluma / Peça complementar da lança / Промежуточная секция стрелы			10,22	1,20	2,08	④ 850
10	1	<b>Ausleger-Kopfstück</b> / Jib head section / Pointe de flèche / Punta braccio / Tramo punta de pluma Cabeça de lança / Концевая секция стрелы			1,40	1,21	0,46	⑨ 80
11	1	<b>Laufkatze</b> / Trolley / Chariot Carrello / Carrito / Carrinho Грузовая тележка			1,62	1,38	1,29	530
12	1	<b>Fahrkorb</b> / Maintenance cage / Nacelle d'entretien Cestello di manutenzione / Plataforma de mantenimiento / Передвижная платформа			0,78	0,66	1,25	35
<b>Turm</b> Tower / Mât / Torre Torre / Torre / Башня								
13	1	<b>Grundturmstück</b> / Base tower section / Mât de base Elemento di torre base / Tramo torre base Peça de base de torre / Секция основания			100 LC 12,00 120 HC 6,85 120 HC 10,00	2,03 1,80 1,80	2,03 1,80 1,80	3820 2610 3530
14	1	<b>Turmstück</b> / Tower section Elément de mât / Elemento di torre Tramo torre / Torre / Башенная секция			3,90 m 100 LC 4,17 5,85 m 100 LC 6,12 11,70 m 100 LC 11,97 120 HC 2,50 120 HC 5,00 120 HC 10,00 120 HC 12,50	1,80 1,80 1,80 1,80 1,80 1,80 1,80	1,80 1,80 1,80 1,80 1,80 1,80 1,80	1190 1620 2930 1090 1830 3430 4200
15	1	<b>Kletterturmstück</b> / Climbing tower section Elément de hissage de mât / Elemento torre di telescopaggio / Tramo de trepado Tramo de telescopagem / Секция самоподъема			120 HC 2,75 100 LC 4,17	2,20 2,26	2,45 2,26	1450 1440
<b>Klettereinrichtung</b> Climbing equipment / Equipement de télescopage / Attrezzatura per allungamento della gru Equipo de trepado / Acedórios p. subida no edificio / Обойма наращивания								
16	1	<b>Führungsstück kpl.</b> / Guide section cpl. / Cage télescopique cpl. / Gabbia di sopraelevazione compl. Torre de montaje completa / Peça de guia compl. Направляющая секция в сб.			100 LC 8,74 120 HC 6,45 120 HC 9,60	2,27 2,10 2,10	2,35 2,42 2,42	3130 3500 4440
17	1	<b>Hydraulikanlage, Stütz- und Klettertraverse</b> / Hydraulic unit, supporting and climbing cross members / Système hydraul. avec traverses d'appui et de télescop. Sist. idraul., traversa di appoggio e allugam. gru / Sistema hidráulico con traviesa de apoyo y trepado / Instalação hidráulica, tavessa de apoio e subida / Гидроагрегат, стойка-упор и траверса обоймы наращивания			100 LC 2,00 120 HC 2,87	0,90 2,12	0,80 1,06	640 1050
<b>Fundamentkreuz</b> Cruciform base / Châssis en croix / Crociera Carro de guindaste / Base cruciforme / Фундаментная крестовина								
18	1	<b>Tragholm I</b> / Arm I / Longeron I Longherone I / Travessa I Braço I / Несущая балка I			(3,8 m) 100 LC 5,68 (4,5 m) 100 LC 6,67 120 HC 7,12	0,71 0,71 0,78	0,91 0,91 0,65	2090 2190 950
19	1	<b>Tragholm II</b> / Arm II / Longeron II Longherone II / Travessa II Braço II / Несущая балка II			(3,8 m) 100 LC 5,68 (4,5 m) 100 LC 6,67 120 HC 3,45	0,78 0,78 0,56	0,74 0,74 0,55	1870 1970 408
20	2	<b>Fahrschemel mit Antrieb</b> / Rail bogie with drive Bogie moteur / Telajo con gruppia propulsore Caja rodillo motriz / Quadra sem grupa de propulsão Подрамник с приводом			100 LC 1,31 120 HC 1,38	0,66 0,88	0,61 0,87	630 900
21	2	<b>Fahrschemel ohne Antrieb</b> / Rail bogie without drive Bogie fou / Telajo senza gruppia propulsore / Caja rodillo conducido / Quadra com grupa de propulsão Подрамник без привода			100 LC 1,04 120 HC 1,17	0,33 0,60	0,61 0,87	330 860

\* Einzelgewichte. / Single weights. / Poids individuels. / Singoli pesi. / Pesos unitarios. / Pesos de peças componentes. / Индивидуальный вес.

**Konstruktionsänderungen vorbehalten!** / Subject to alterations! / Sous réserves de modifications! / Reservato il diritto di modifiche strutturali!  
¡Sujeto a modificaciones! / Salvo modificação da construação! / Права на внесение конструкторских изменений сохраняются!

**Sämtliche Angaben erfolgen ohne Gewähr.** / This information is supplied without liability. / Ces renseignements sont sans garantie. / Tutte le indicazioni fornite senza garanzia. / Declinamos toda responsabilidad derivada de la información proporcionada. / Declinamos qualquer responsabilidade quanto à informação fornecida. / Все данные указаны без обязательств.

121 P – 5843 • EN 14439:2009 – DIN 15018-H1/B3 • BGL C.0.10.0090 • 04.10 / 7

Printed in Germany.