

**Tower Crane
Grue à tour**

Turmdrehkran 20 K

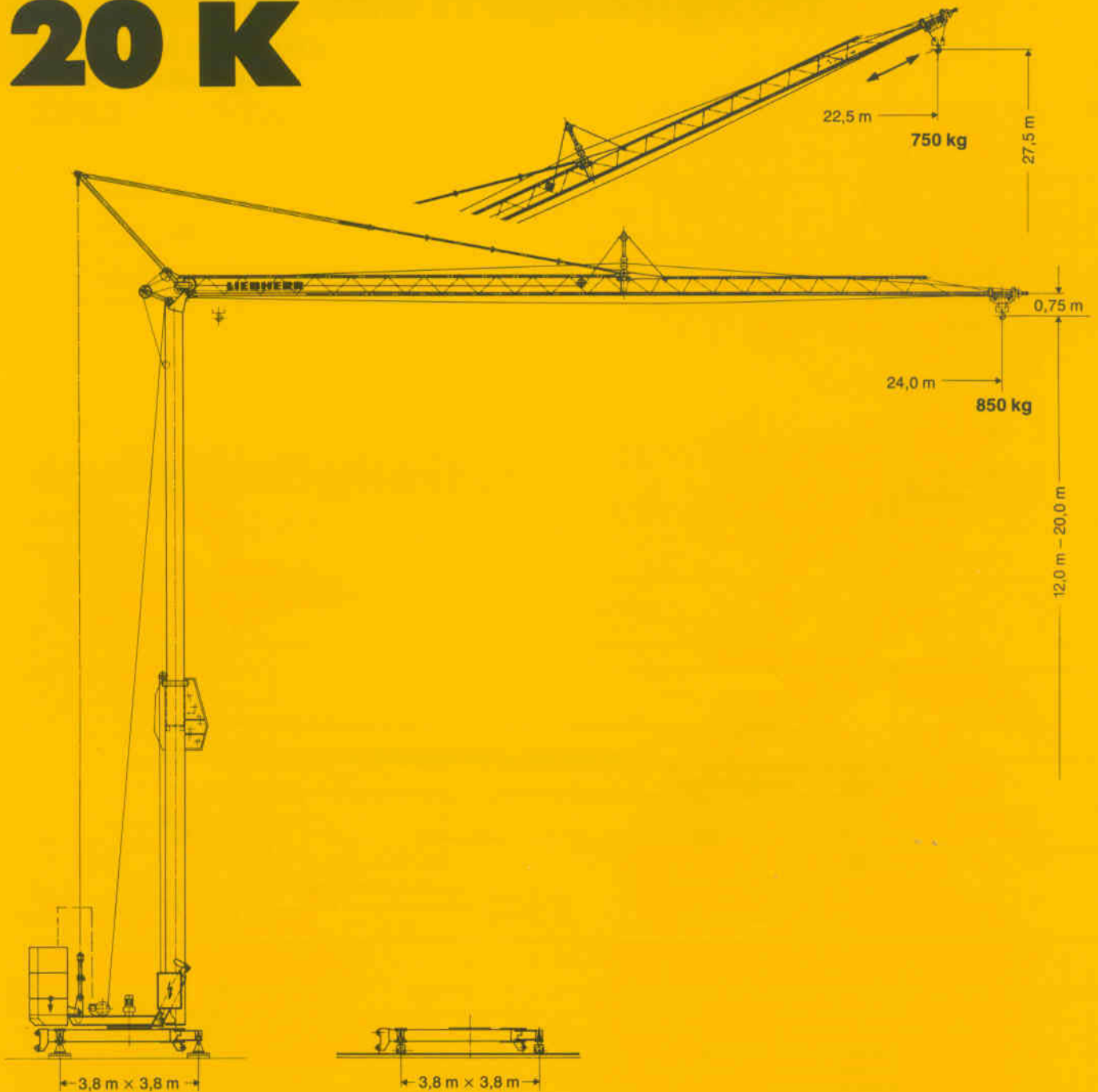

LIEBHERR

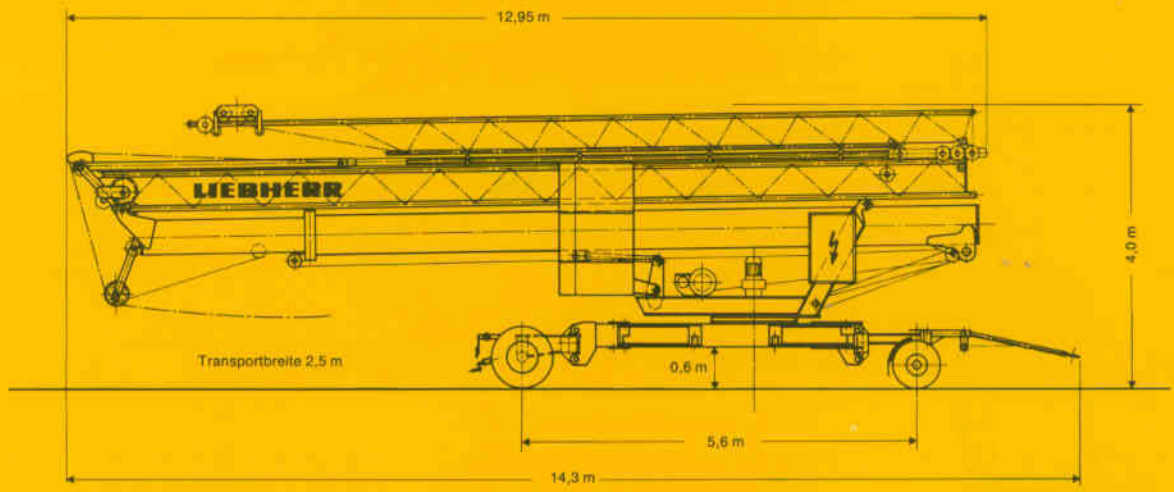
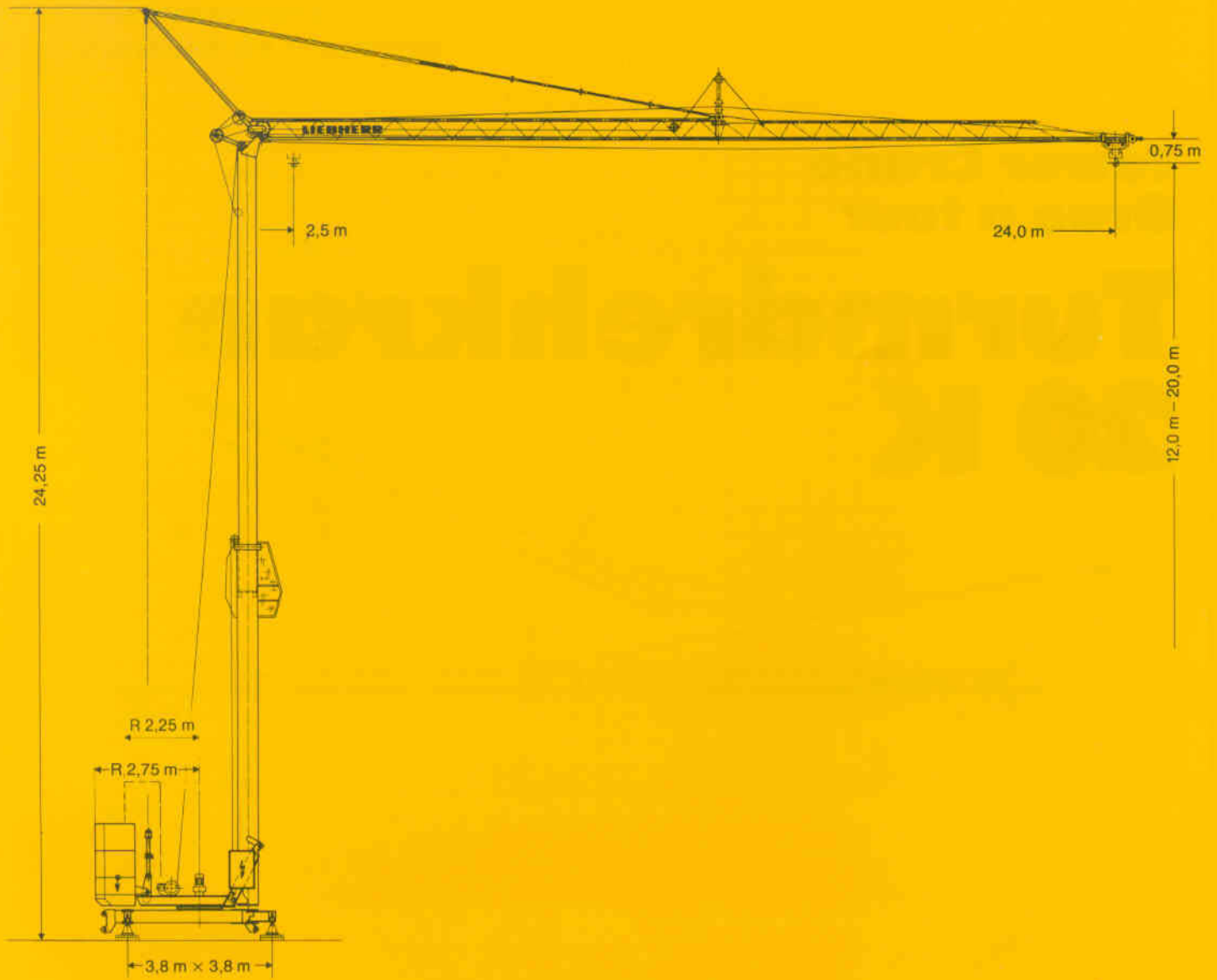

Transportgewicht 17000 kg
 Transport weight
 Poids de transport

20 K

Gewicht

Weight

Poids

Gegengewicht ca. Counter weight approx. Contrepoids env.	R 2,75 m	8500 kg
Gegengewicht ca. Counter weight approx. Contrepoids env.	R 2,25 m	10000 kg

Konstruktionsgewicht ca. Dead weight approx. Poids de la construction env.	8400 kg
--	---------

Ausladung und Tragfähigkeit

Radius and capacity

Portée et charge

Auslegerlänge Length of jib Longueur de flèche m	Max. Tragfähigkeit Max. capacity Charge maxi. m/kg	Ausladung und Tragfähigkeit m/kg Radius and capacity Portée et charge														
		10,0	11,0	12,0	13,0	14,0	15,0	16,0	17,0	18,0	19,0	20,0	21,0	22,0	23,0	24,0
24,0	2,5 – 11,7 2000	2000	2000	1945	1765	1615	1490	1380	1280	1195	1125	1055	995	945	895	850

Geschwindigkeiten

Speeds

Vitesses

	U/min 0 – 0,9 sl./min tr./mn	1,5 kW
	30,0 m/min 30,0 m/min	1,1 kW 3,0 kW Auslegersteilstellung Elevated jib Flèche inclinée
	25,0 m/min	2 × 1,0 kW

Hubwerk Hoist unit Mécanisme de levage	Stufe Step Cran	kg	m/min
	1	2000	5,0
	2	2000	20,0
	3	1300	40,0

Kabelquerschnitt bei 380 V bis 28,0 m 4 × 10 mm²
Cross section of cable up to
Section de câble à jusqu'à

Betriebsspannung 380 V
Operating voltage
Tension de service

Frequenz 50 Hz
Frequency
Fréquence

Gesamtmotorenleistung max. 15,6 kW / 19,5 kVA
Total motor output
Puissance totale des moteurs

Technische Kenngröße nach BGL
Technical nominal size according to the construction machinery list (BGL)
Grandeur caractéristique suivant le barème d'emploi des appareils (BGL)



2108-0020

Technische Daten - Technical data

Caractéristiques techniques

Aufstellvorgang

Erection procedure

Déroulement de montage

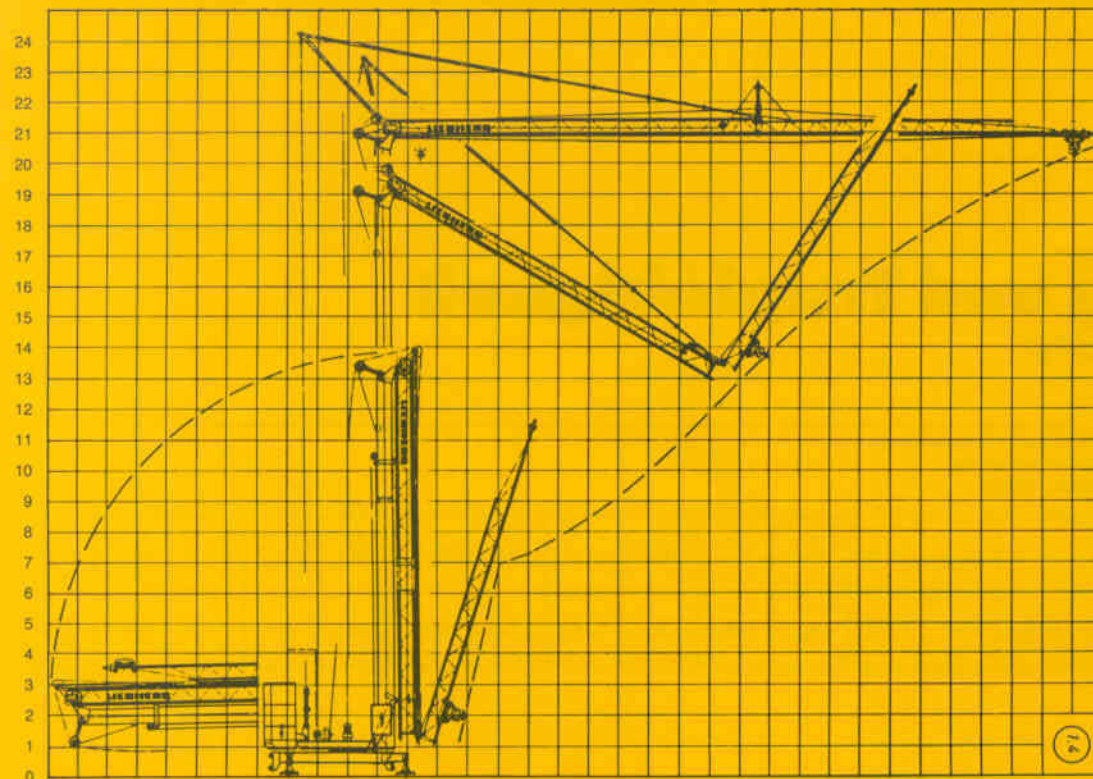

10 9 8 7 6 5 4 3 2 1 0 1 2 3 4 5 6 7 8 9 10 11 12 13 14 15 16 17 18 19 20 21 22 23 24 25



Kolli-Liste

Packing list

Liste de colisage

Pos. Item Rep.	Anzahl Quantity Qté.	Benennung Description Designation		Länge m Length m Longueur m	Breite m Width m Largeur m	Höhe m Height m Hauteur m	Einzelgew. kg Unit weight kg Poids unitaire kg	Gesamtg. Total weight kg Poids total kg
1	1	Transportachse vorne Tra 50 KW 1 Road transport axle front Essieux de transport avant		3,10	1,42	0,98		465
2	1	Transportachse vorne Tra 100 KY 1 Road transport axle front Essieux de transport avant		3,00	1,13	0,97		660
3	1	Transportachse hinten Tra 120 GY 1 Road transport axle behind Essieux de transport arrière		1,90	2,50	1,05		1150
4	1	Kiste mit Seilen und Kleinteilen Case with ropes and small parts Caisse avec câbles et pièces détachées		1,00	0,80	1,00		450

Datenblatt Nr. 120P - 2490 - H1 B3 DIN 15018 und OENORM T3 - 9.86
Data sheet

Feuille de caractéristiques

Konstruktionsänderungen vorbehalten!
Subject to alterations!
Sous réserves de modifications!

Printed in Austria

Nehmen Sie Kontakt auf mit
Contact

Mettez-vous en rapport avec

LIEBHERR-WERK BIBERACH GMBH, Postfach 1663, D-7950 Biberach an der Riss 1,
Telefon (0735 1) 41-0, Telex 7 1802